

Main Panel to	External Devices	Cable	Size: Power/Line	Maximum Length
	SI Module	Device Net Cable	AWG22/24	30m
Discharge Module	Device Net Cable	AWG22/24	30m	
Manual Release	Device Net Cable	AWG22/24	30m	
Horn & Strobe	Twisted Pair	AWG18	30m	
Solenoid Actuator	Twisted Pair	AWG18	15m	
Battery	Twisted Pair	AWG18	10m	

Interlock Relay Output Specification
 Contact Rating: 60W, 125VA Max.
 Maximum Voltage: AC250V, DC200V
 Maximum Current: 1A

Relay contacts are shown in the normal condition, with power on, no faults, and no alarm.

Normal 1-2, 21-22 Short
 Fire Alarm 0-2, 20-22 Short
 Normal 4-5, 24-25 Short
 Pre-Discharge 3-5, 23-25 Short
 Normal 7-8, 27-28 Short
 Fault 6-8, 26-28 Short

Terminal Block Size: M3
 Torque 0.5 - 0.75 Nm

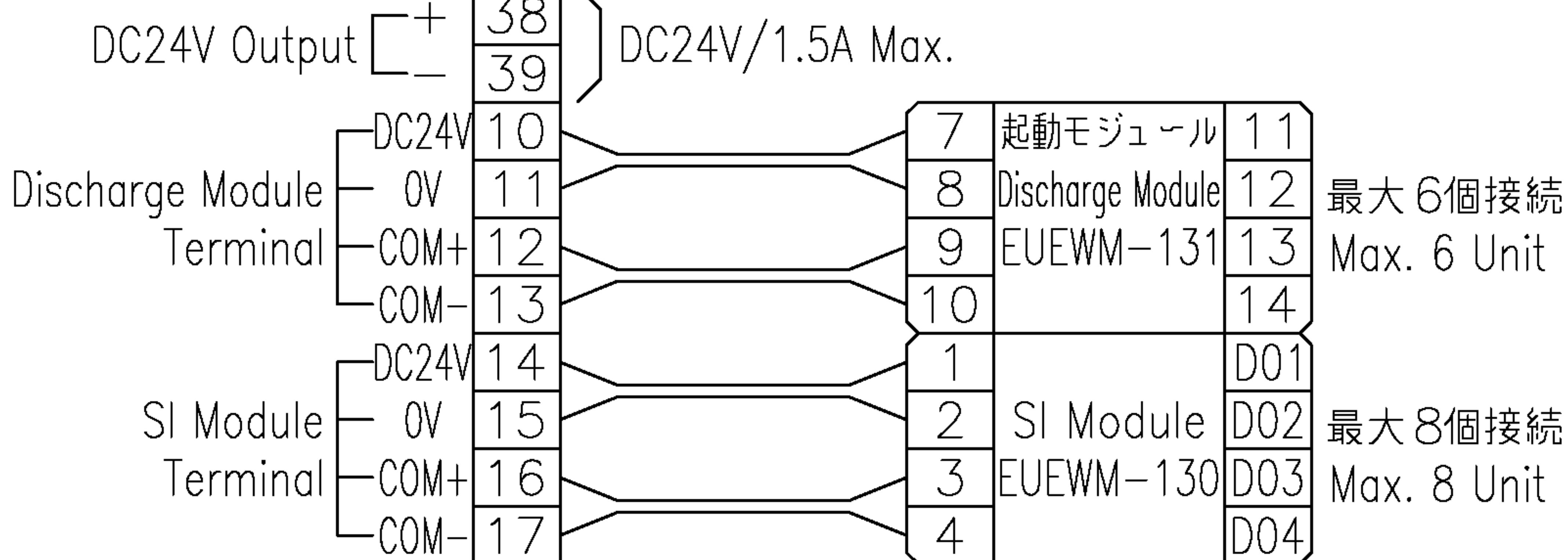
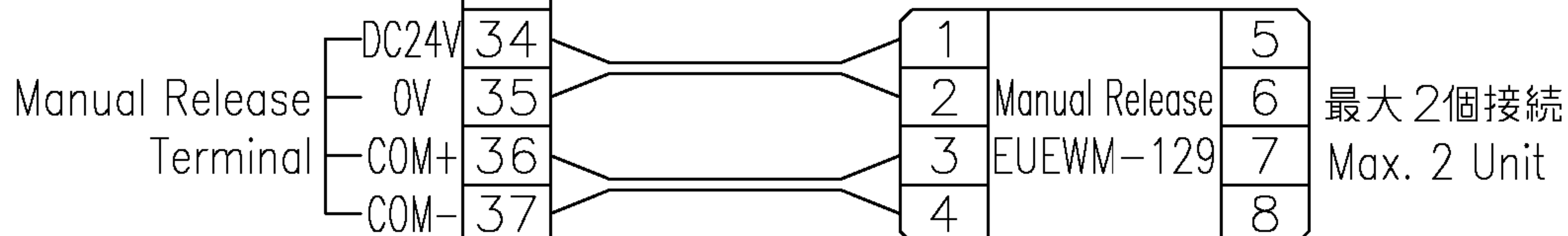
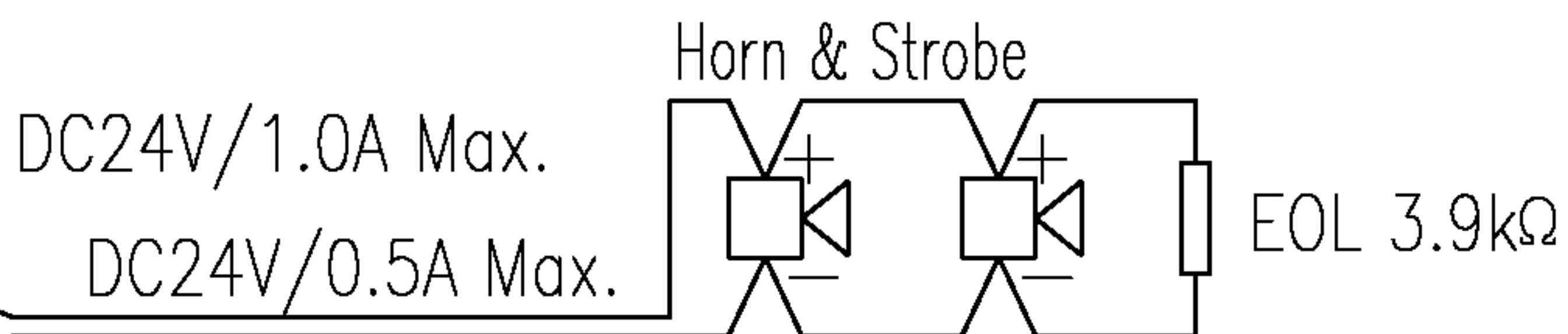

Total Current: 3.0A Max.

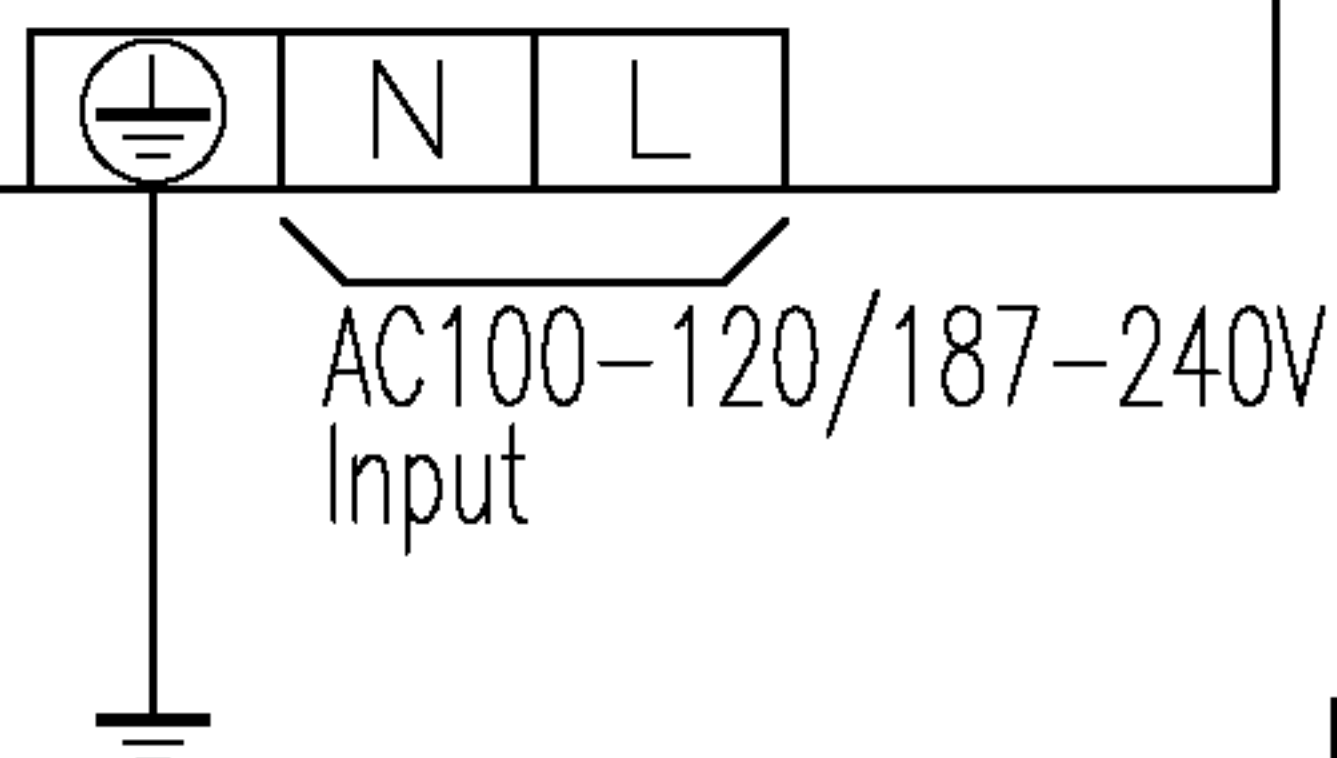
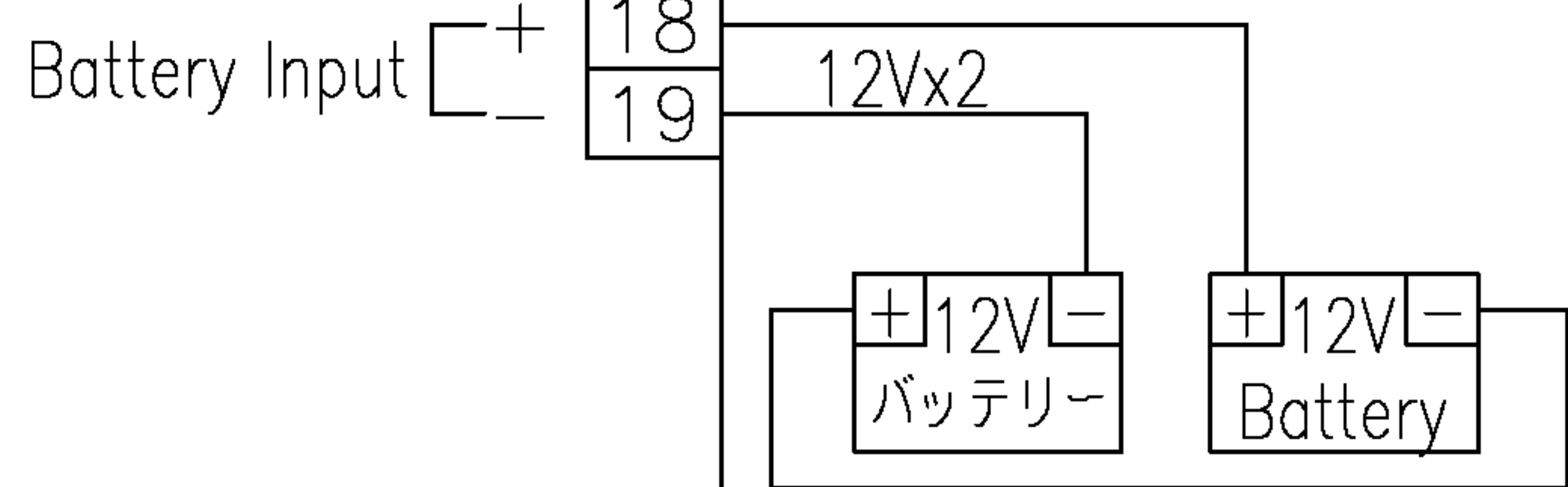

No.	Parts Name (部品名)	Material (材質)	Q'TY	Remarks (備考)
Date (日付)		Scale (尺度)	DSGN'D (設計)	CHK'D (検閲)
APRV'D (承認)				
Drawing No. (図番)				
CXR-23901-2				

CABINEX-EWT Main Panel
 Wiring Diagram
 Model(型式): -

2006.11.09
 HATSUTA SEISAKUSHO CO.,LTD.
 (株) 初田製作所

MC Atsumi Tani
 Drawing No. (図番)
 CXR-23901-2

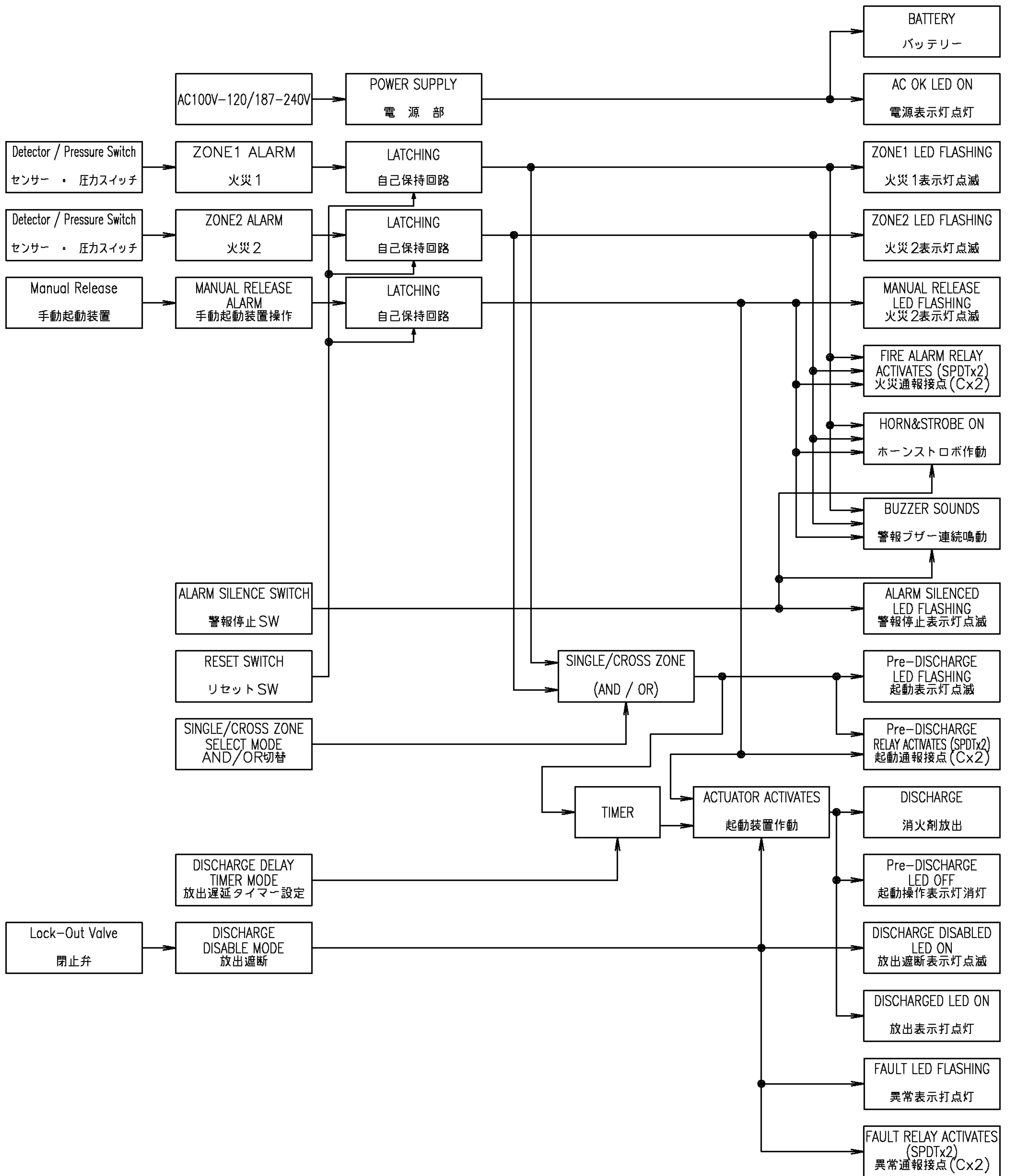

△ -	-	-	-	-	-
△ -	No.	Parts Name (部品名)	Material (材質)	Q'TY	Remarks (備考)
△ -	Date (日付)	Scale (尺度)	DSGN'D (設計)	CHK'D (検閲)	APRV'D (承認)
CABINEX-EWT Main Panel Alarm Logic sequence	2010.02.12	-	Shimada	Iwanishi	Kosakai
Model(型式): -	HATSUTA SEISAKUSHO CO.,LTD. (株) 初田製作所		Drawing No. (図番) CXR-23902-2		

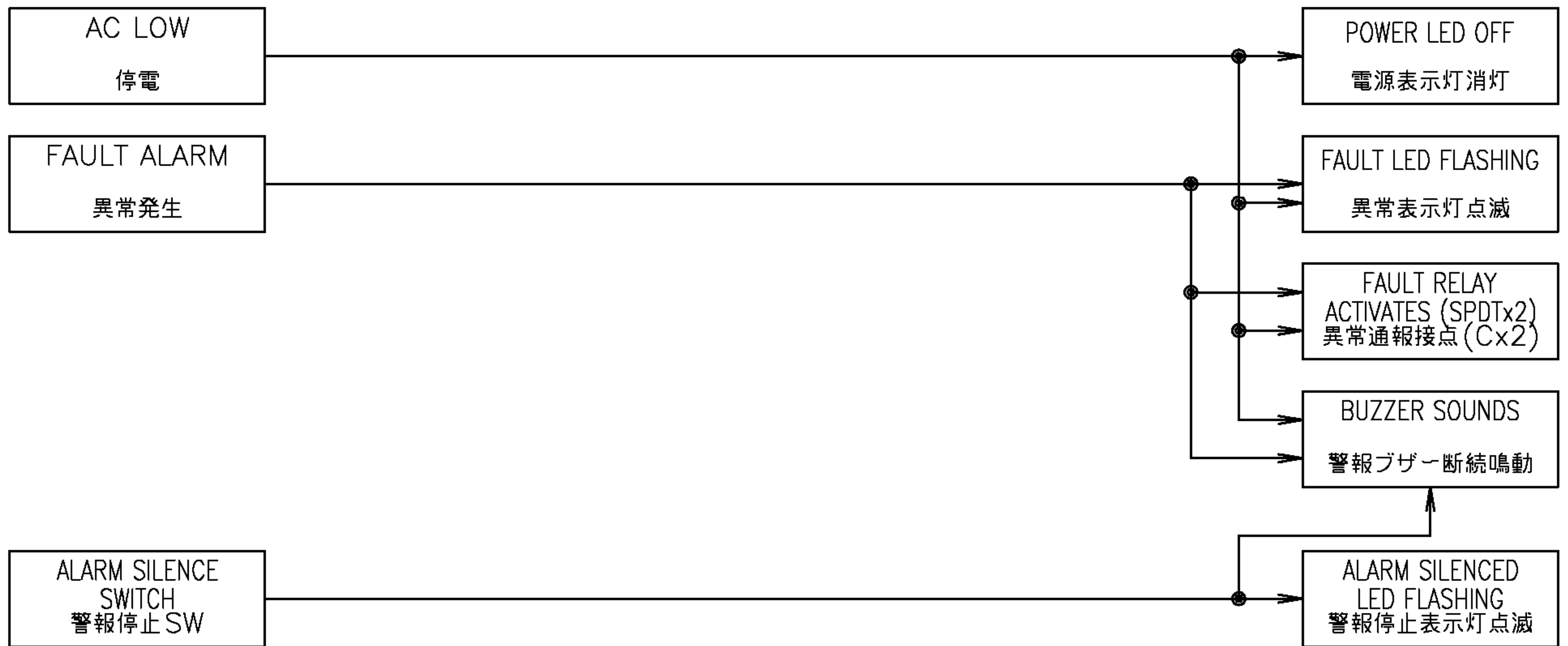

CABINEX-EWT Main Panel
Fault Logic sequence

Model(型式): -

No.	Parts Name (部品名)	Material (材質)	Q'TY	Remarks (備考)
	Date (日付)	Scale (尺度)	DSGN'D (設計)	CHK'D (検図) APRV'D (承認)
	2003.01.16	-	KATAOKA	KATAOKA NISHIMOTO
HATSUTA SEISAKUSHO CO.,LTD. (株) 初田製作所			Drawing No. (図番) CXR-23903	

Main Panel to	External Devices SI Module	Cable Multiple Pair (Shielded) 多対	Size AWG22	Maximum Length 30m
---------------	-------------------------------	--------------------------------------	---------------	-----------------------

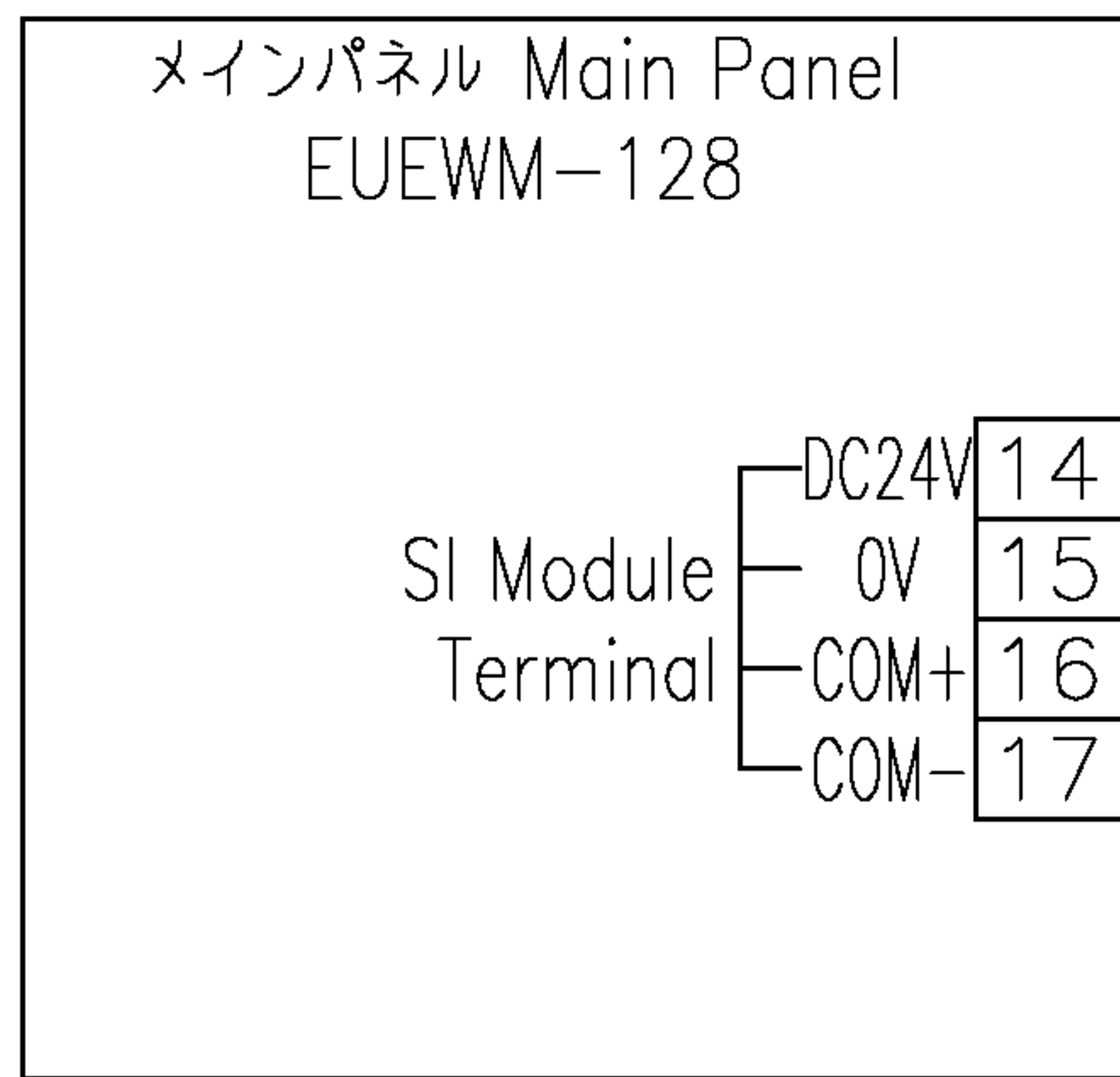

Terminal Block Size: M3
Torque 0.5 - 0.75 Nm

最大 8 個接続
Max. 8 Unit

Following Detectors Available
 Flame detector: SX-7000 series
 Heat Detector: THIS series
 Normally Open Contact Type Detector*
 Normally Open Contact Type Manual Release*
 * End of Line Resistor (100k) required

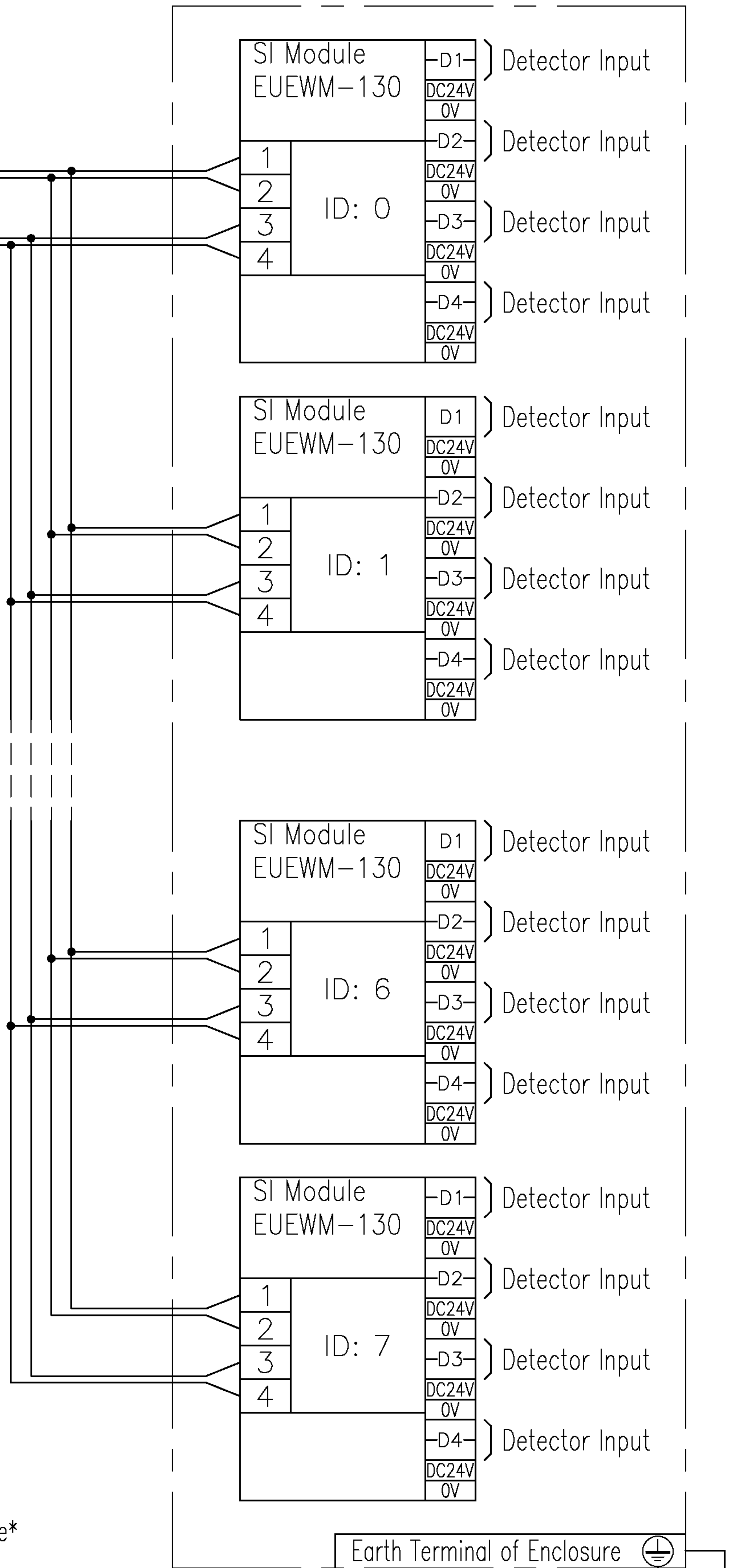

CABINEX-EWT SI Module
Wiring Diagram
Model(型式): -

No.	Parts Name (部品名)	Material (材質)	Q'TY	Remarks (備考)
	Date (日付)	Scale (尺度)	DSGN'D (設計)	CHK'D (検閲)
	2004.10.07	-	MC	Kumazawa Tani
HATSUTA SEISAKUSHO CO.,LTD. (株) 初田製作所			Drawing No. (図番) CXR-24101-1	

Main Panel to	External Devices Discharge Module	Cable Multiple Pair (Shielded) 多対	Size AWG22	Maximum Length 30m
---------------	-----------------------------------	-----------------------------------	------------	--------------------

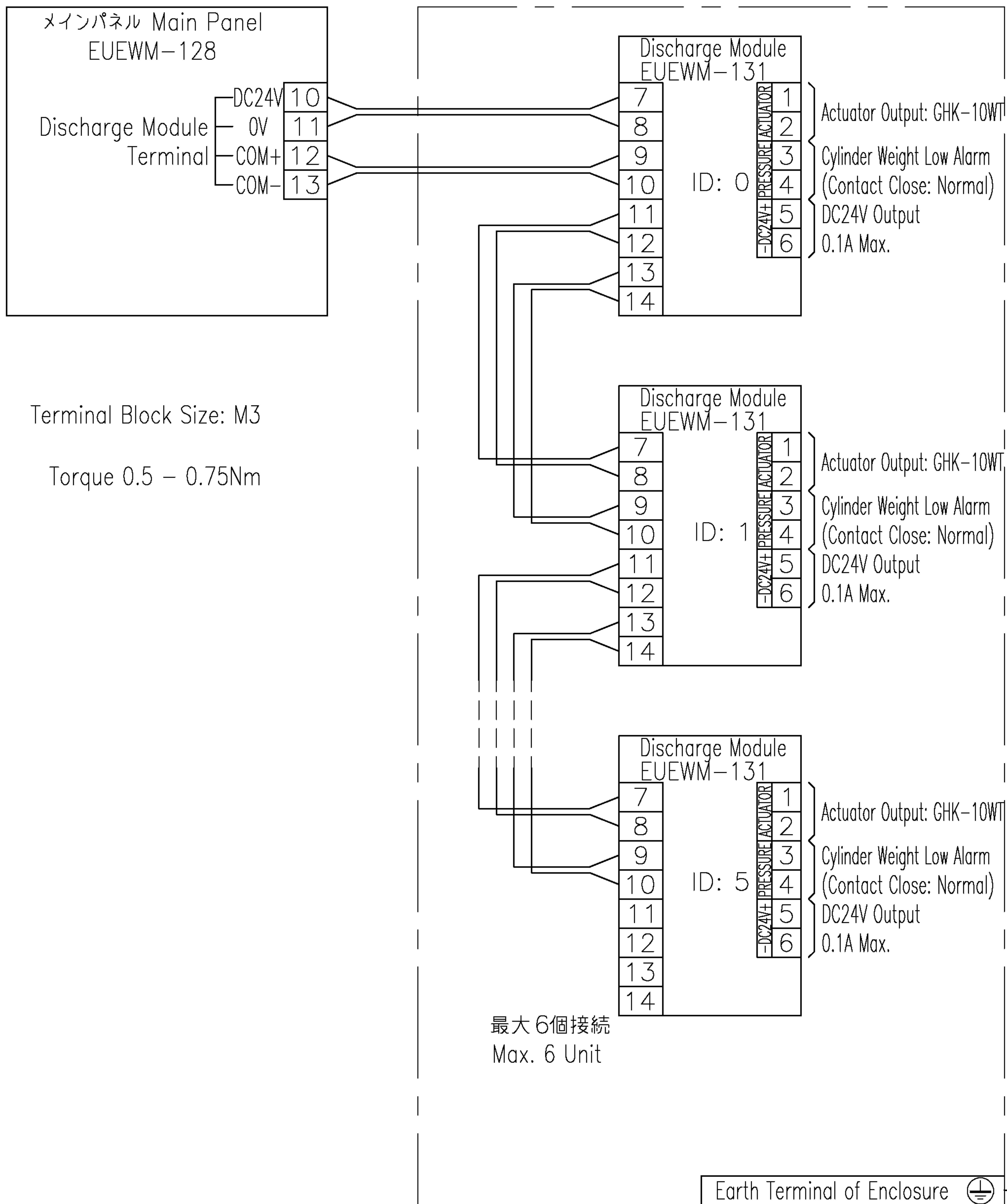

Terminal Block Size: M3

Torque 0.5 - 0.75Nm

CABINEX-EWT Discharge Module Wiring Diagram

Model(型式): -

No.	Parts Name (部品名)	Material (材質)	Q'TY	Remarks (備考)
	Date (日付)	Scale (尺度)	DSGN'D (設計)	CHK'D (検閲) APRV'D (承認)
	2004.10.08	-	MC	Kumazawa Tani
HATSUTA SEISAKUSHO CO.,LTD. (株) 初田製作所			Drawing No. (図番) CXR-24201-1	