

Panel Detail

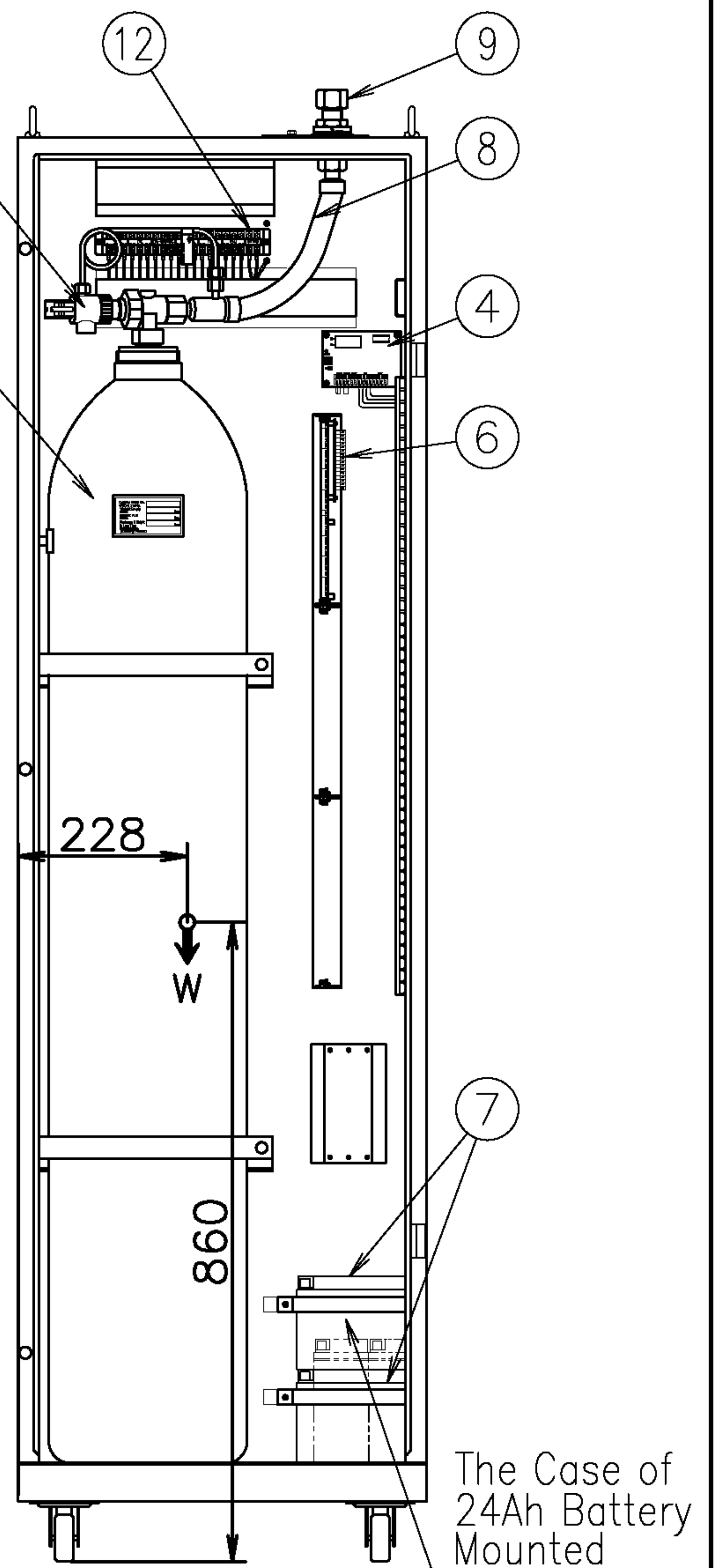

Inside of The Box

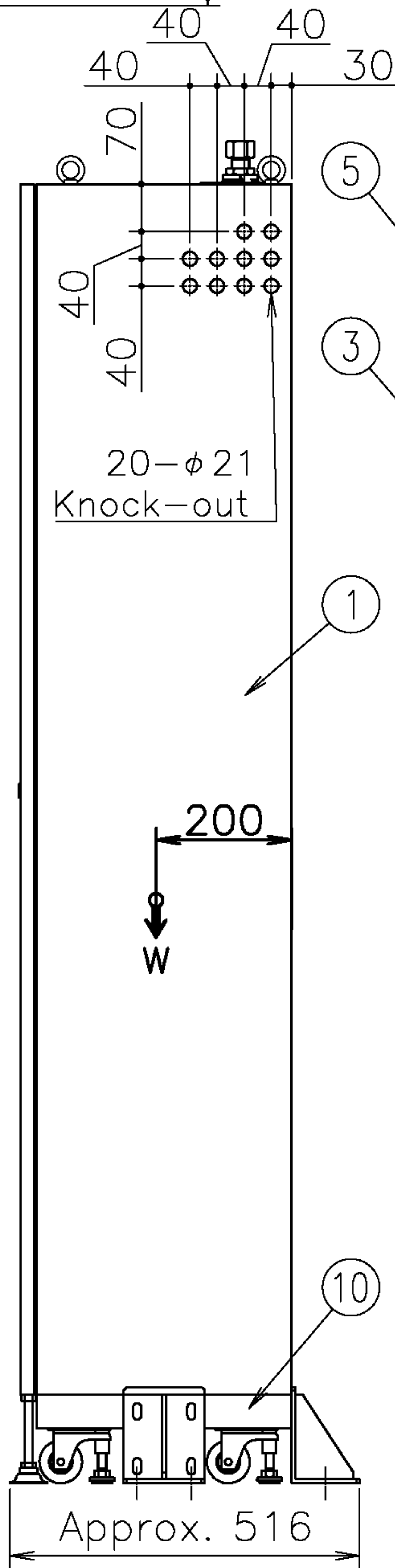
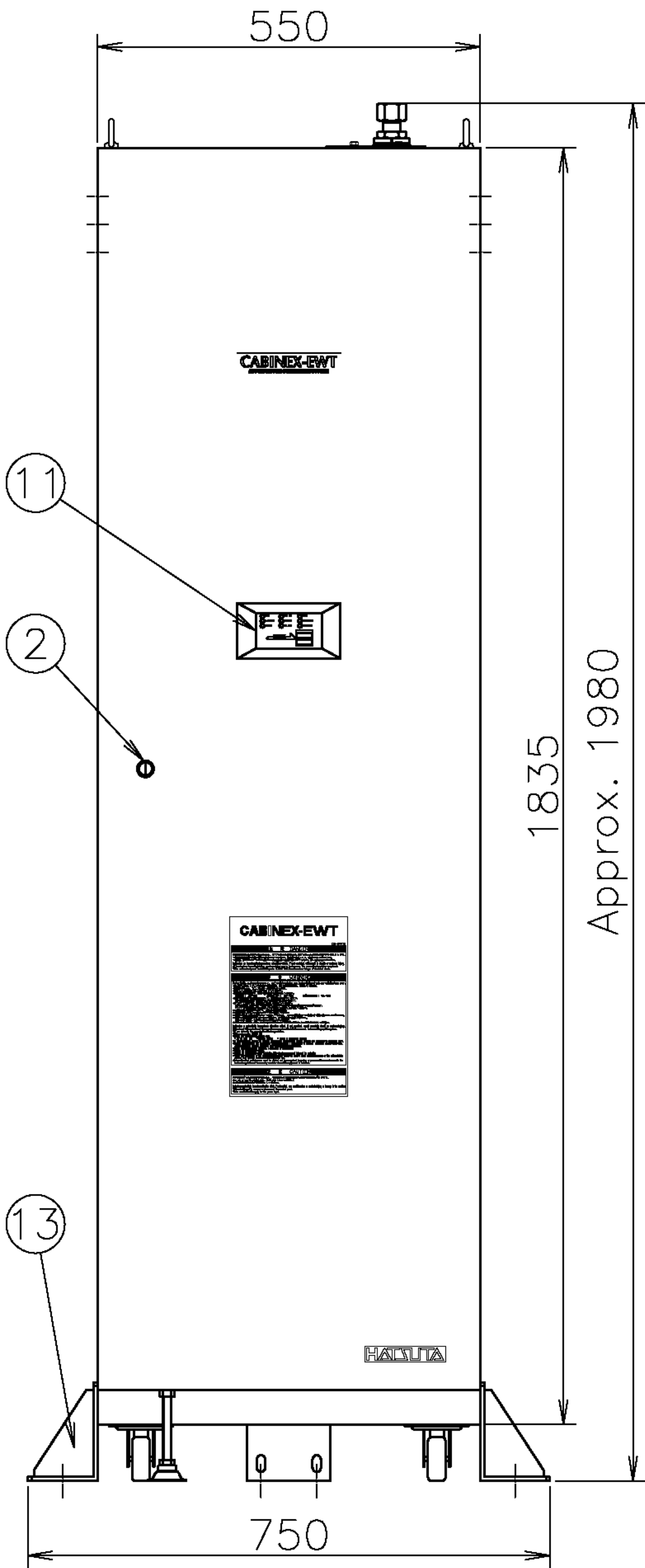
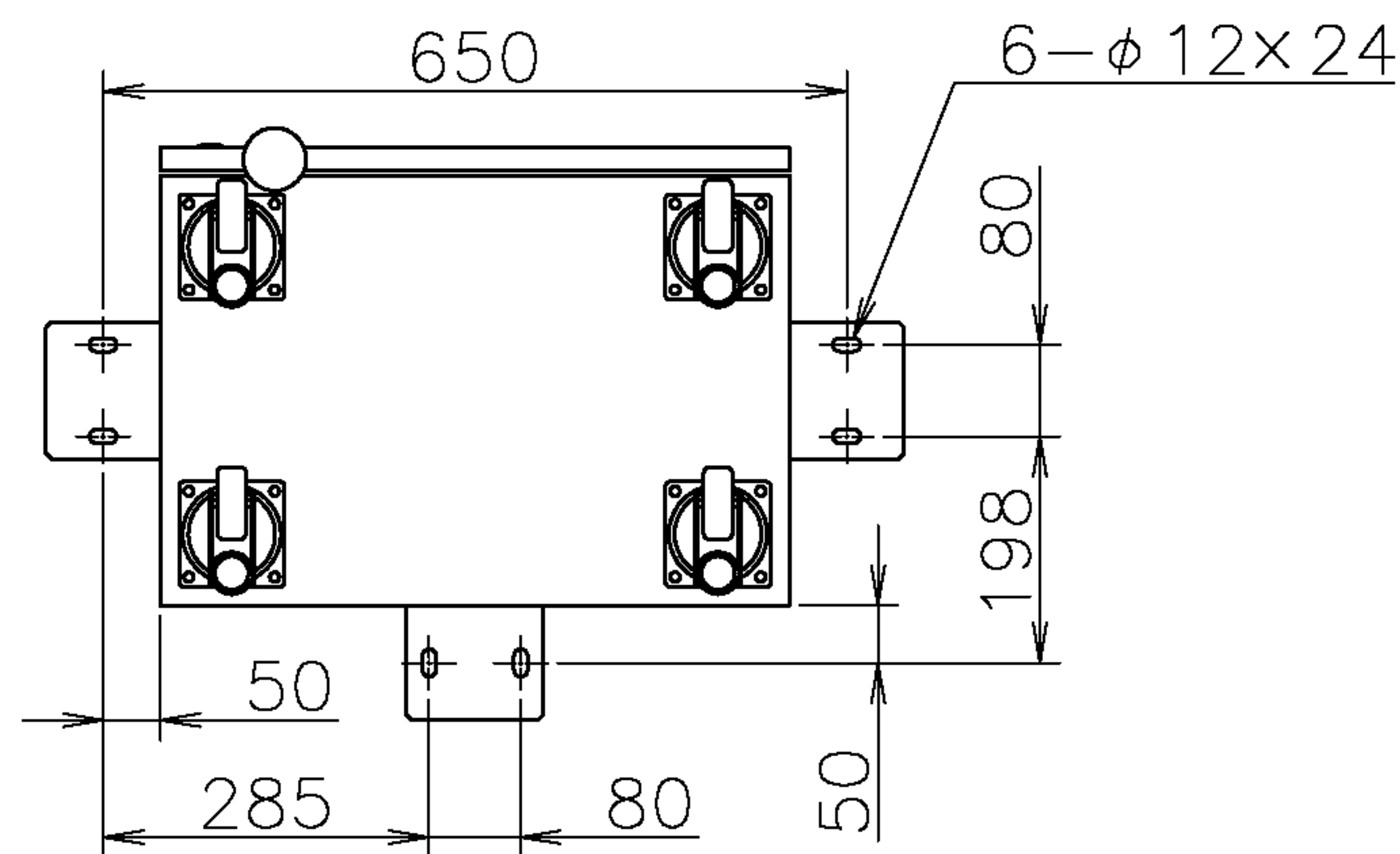

Holes for Anchor

Weight : Approx. 270kg  
FM Approved CO2 System

No.	Parts Name (部品名)	Material (材質)	Q'TY	Remarks (備考)
13	Anchor Bracket	SPCC	3	Color:Red
12	Terminal Block	-	1	-
11	Main Panel	-	1	-
10	Base	SPCC	1	Color:Red
9	Union	-	1	1/2"NPT
8	Flexible Hose	-	1	-
7	Battery	-	2	12V(16Ah or 24Ah)
6	SI Module	-	Max.6	-
5	Gas Cartridge Actuator	-	1	-
4	Discharge Module	-	1	-
3	CO2 Cylinder	-	1	100LB (45.4kg)
2	Lock	-	2	-
1	BOX	SPCC	1	Color:Red

Date (日付)	Scale (尺度)	DSGN'D (設計)	CHK'D (検閲)	APRV'D (承認)
2007.07.04	None	MC	Kosakai	Kataoka
Drawing No. (図番)				CXR-277-10

CABINEX-EWT 100 lb Assembly  
Assembly Name: COX-100EWT

HATSUTA SEISAKUSHO CO.,LTD.  
(株) 初田製作所